

PIANC
APAC
2024

3RD PIANC ASIA PACIFIC
CONFERENCE
27-30 AUGUST 2024
SYDNEY, AUSTRALIA
www.piancapac.com



Cross-Border Collaborative Innovations for Business and Environmentally Sustainable Ports

ZOU Guangrong

VTT Technical Research Centre of Finland

VTT is one of the leading technical research organizations in Europe, and a visionary research and innovation partner for companies and societies.

2,355

employees

1,135

customers

284 M€

operating income

VTT goes beyond the obvious

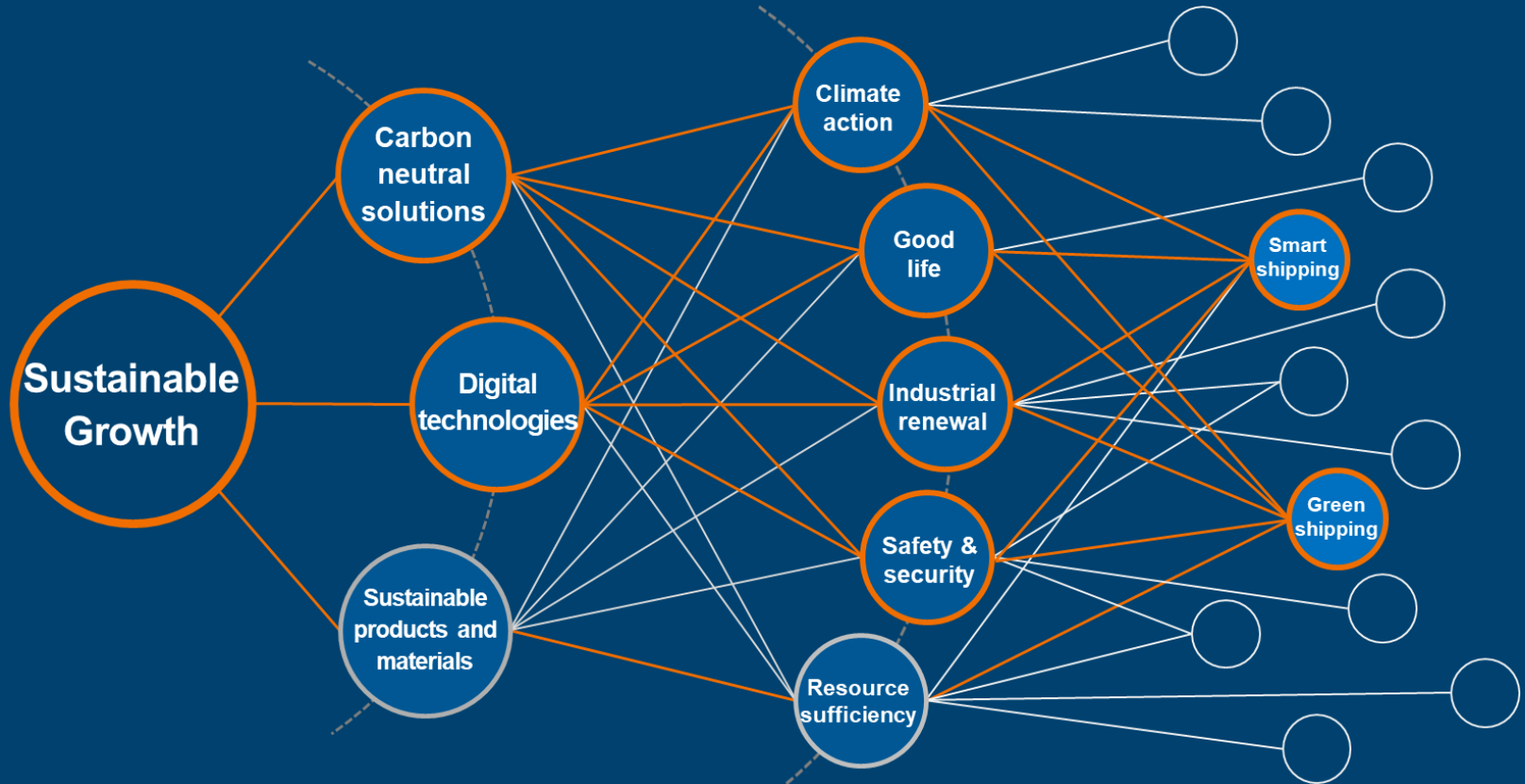

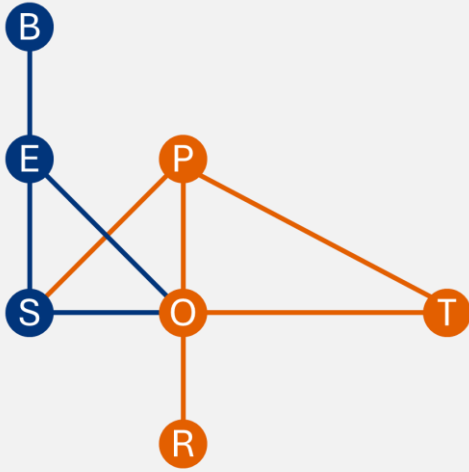

Cross-border
collaborative
innovations for
Business and
Environmentally
Sustainable **PORTs**

Efficient and cost-effective freight transport requires **close collaboration and data sharing** across the entire logistics network.

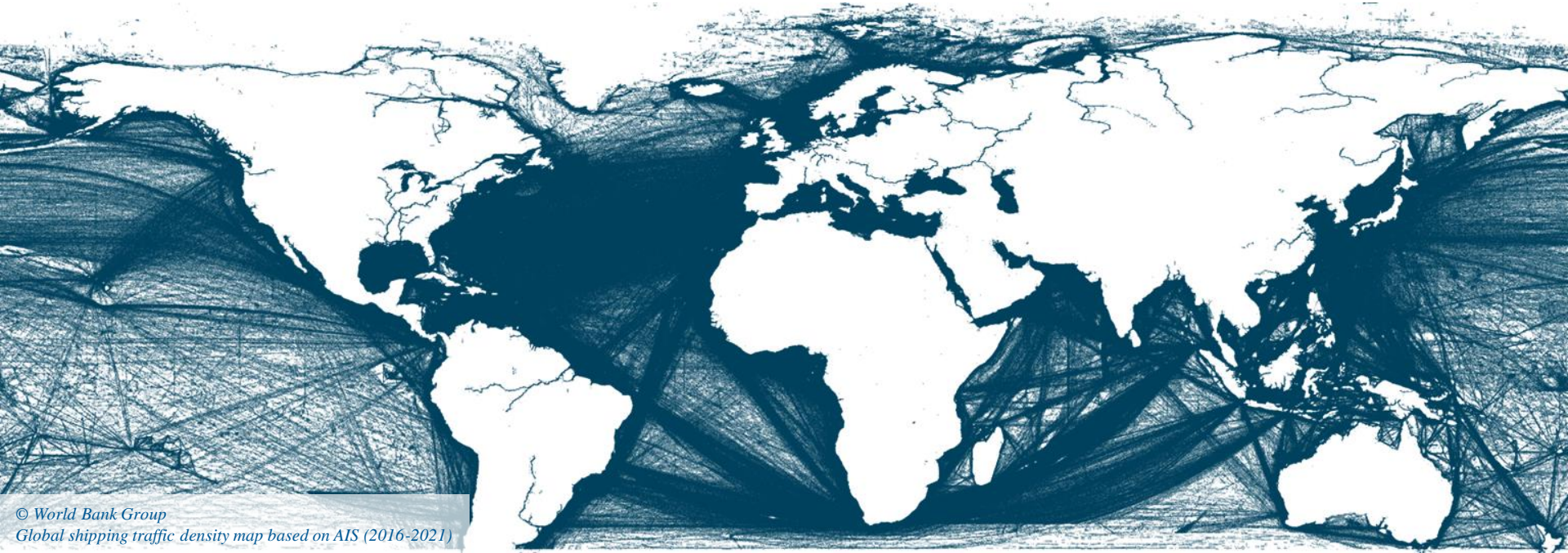

... especially true for seaports as the critical nodes and bottlenecks of global logistics network.

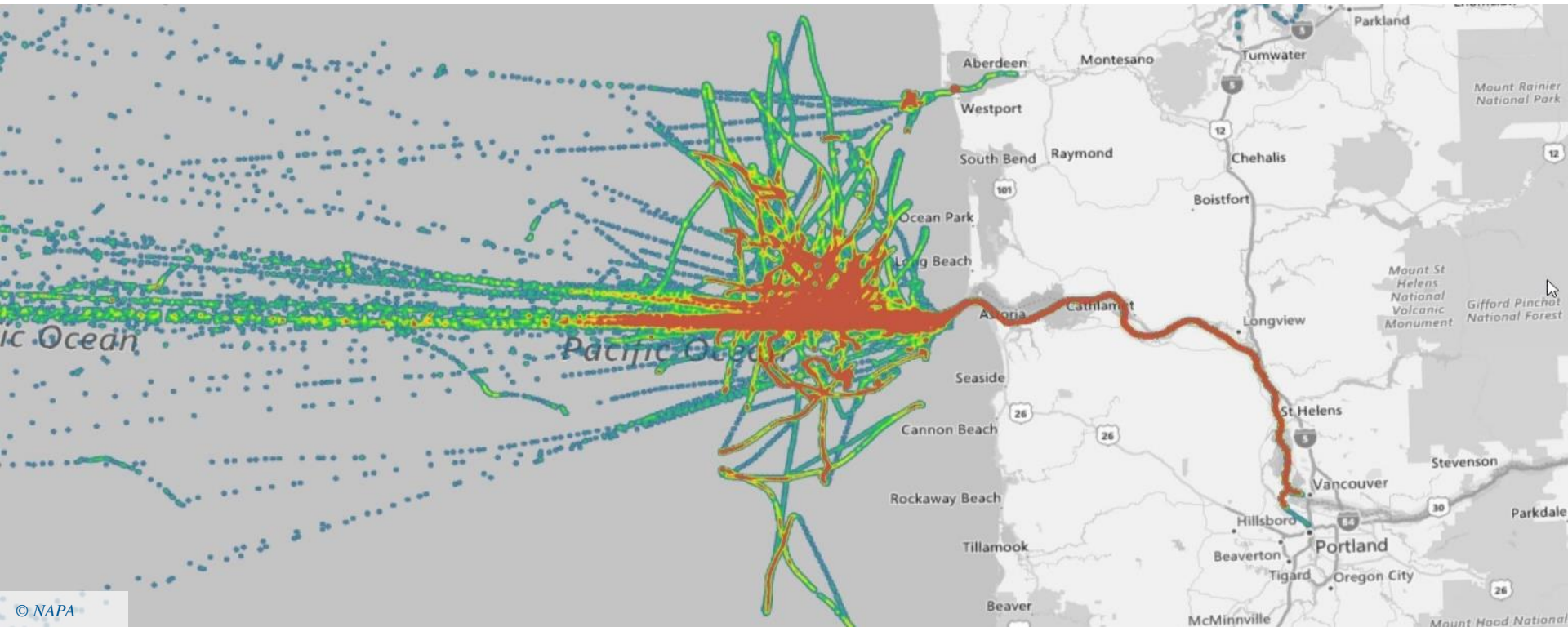

Port operation is of a collaborative nature

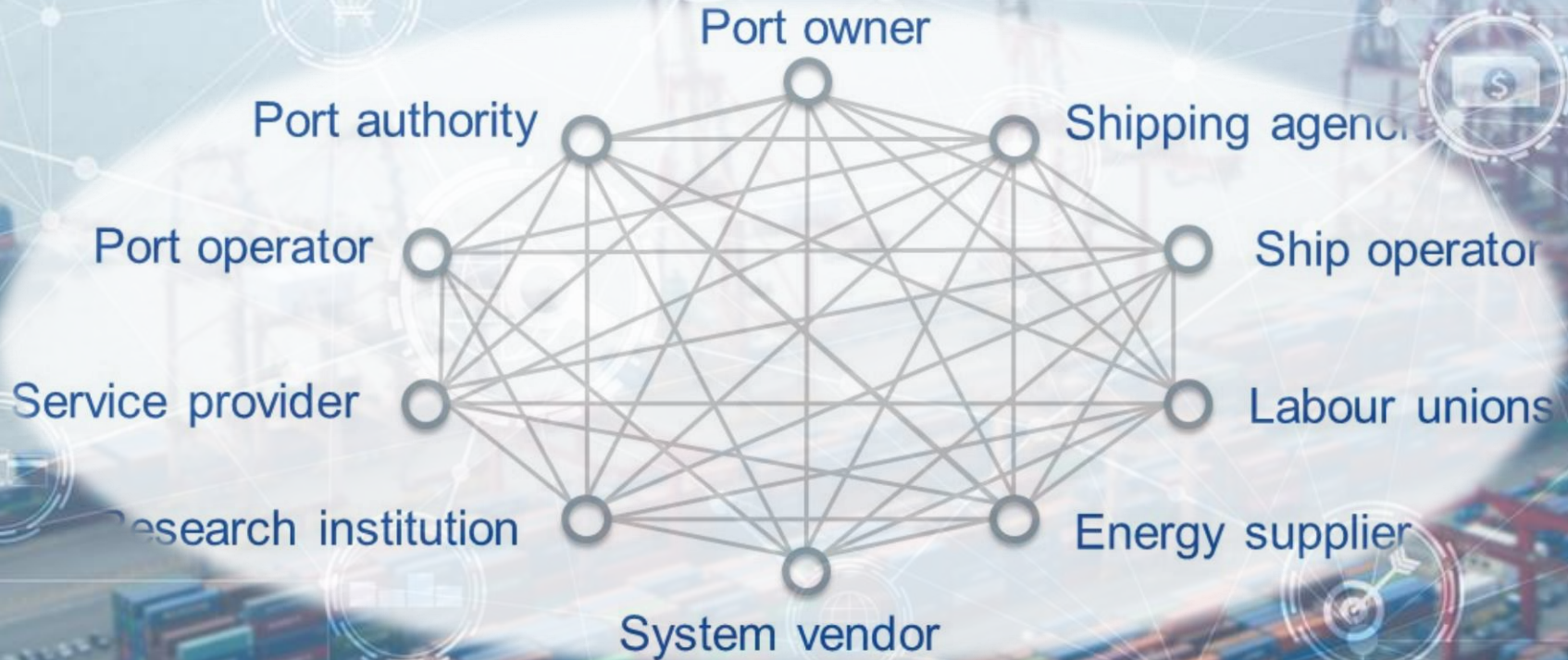

Functional silos cause unnecessary complexities & uncertainties, and consequently unnecessary inefficiencies

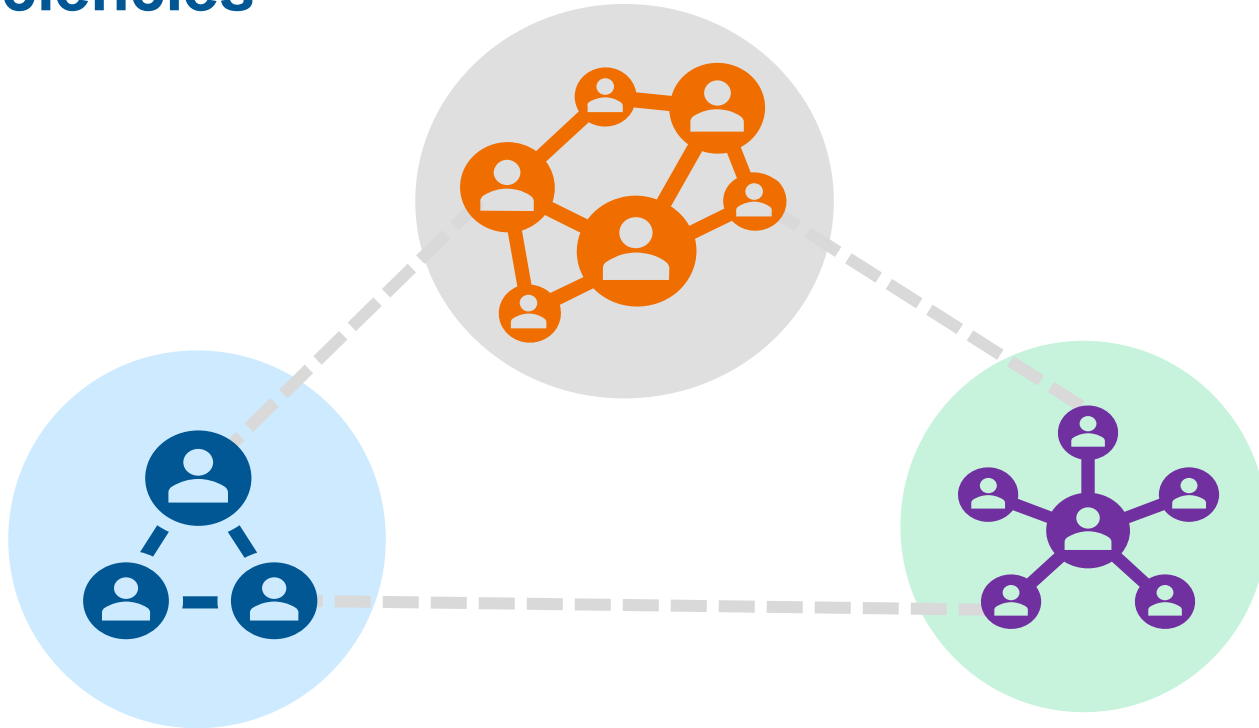

Digital transformation can be an enabler, ... but the **level of readiness and willingness** varies greatly

We have collected a lot of data of our systems, but we don't know how to efficiently use the data



We collaborate with partners, but we don't want to share data, information and knowledge with competitors

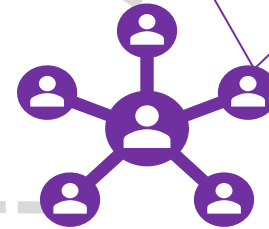

We provide digital models & solutions as a service, but struggle to find partners and customers



Digitalization, decarbonization and automation are shaping the future of port operation globally

 IF

 HOW

AI



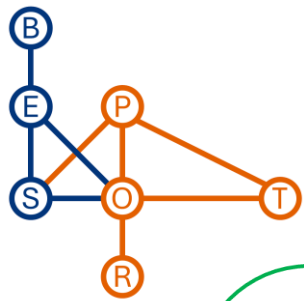

“A Finland-China joint innovation action to address industry’s major challenges and need for **electrification, digitalization and operational optimization** towards smart and green ports.”

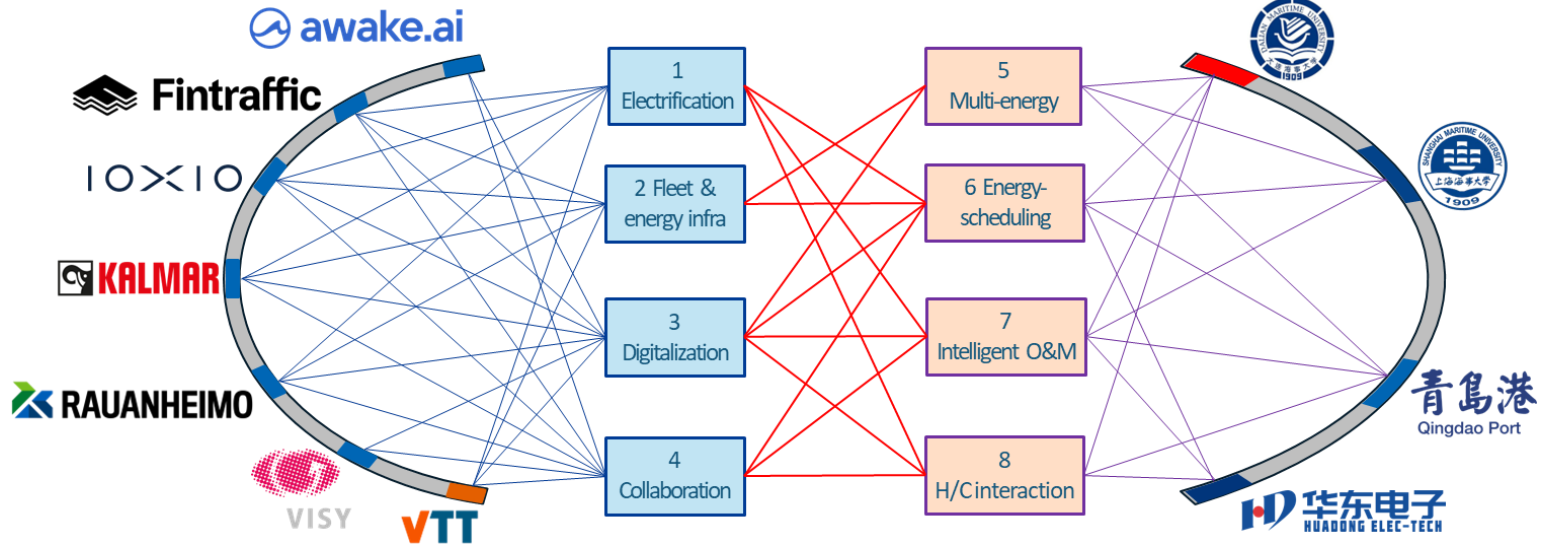

Cross-border collaboration

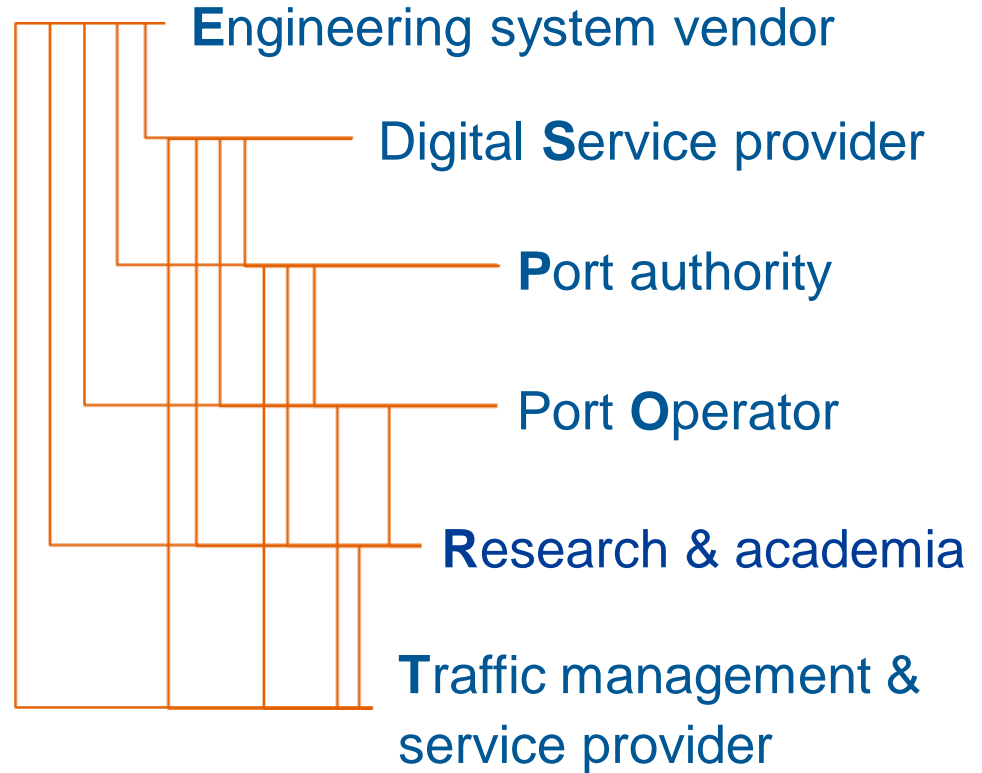
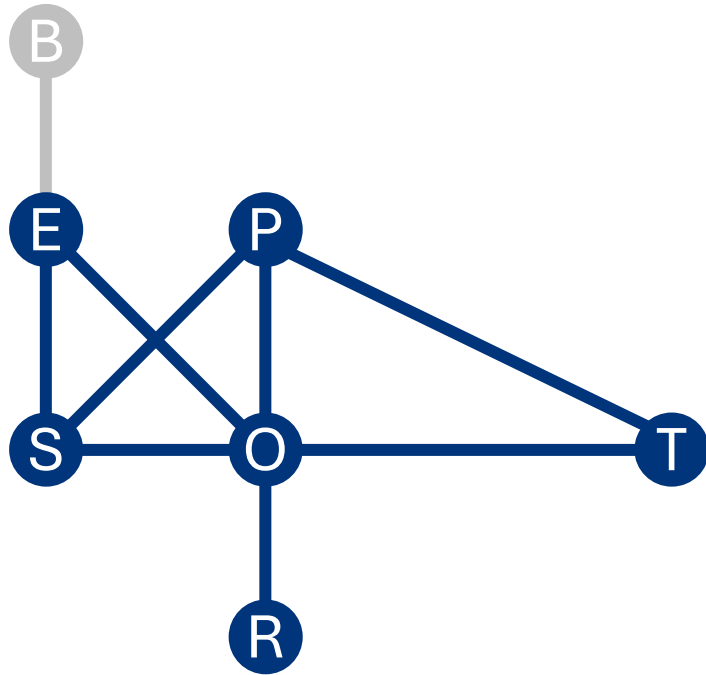

Collaborative innovation

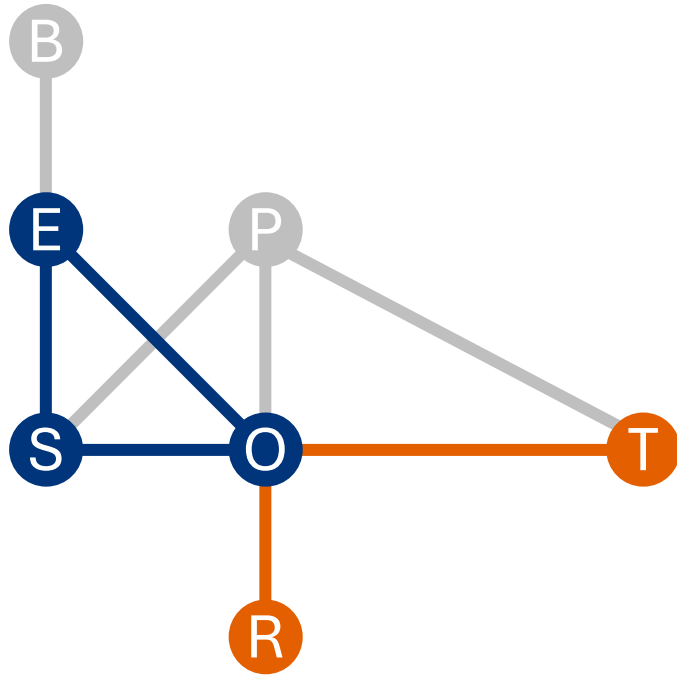

Research →
Technology →

Electrification

Smartization/
Digitalization

Operational
Optimization

Business exploration

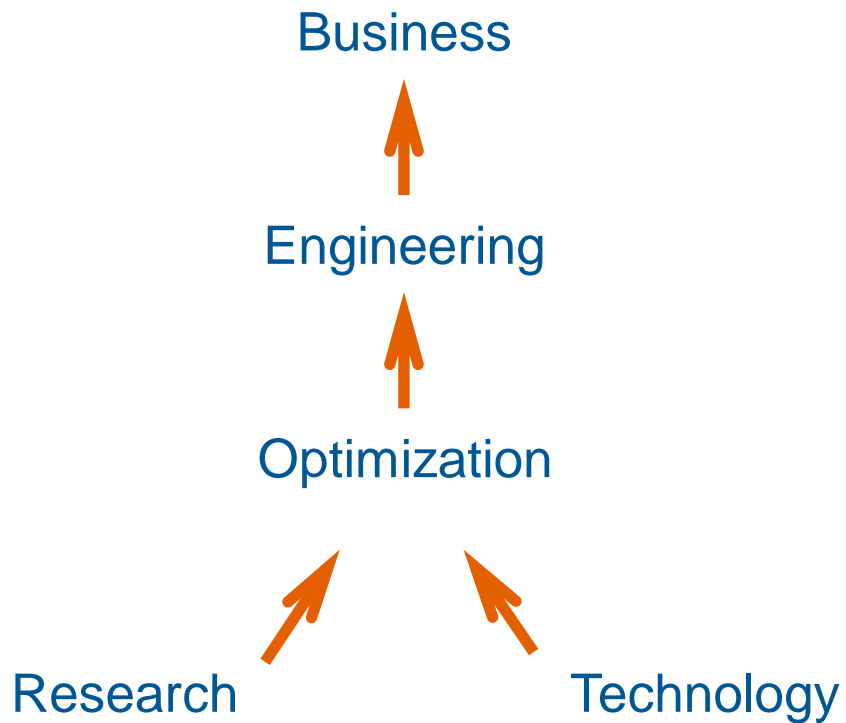
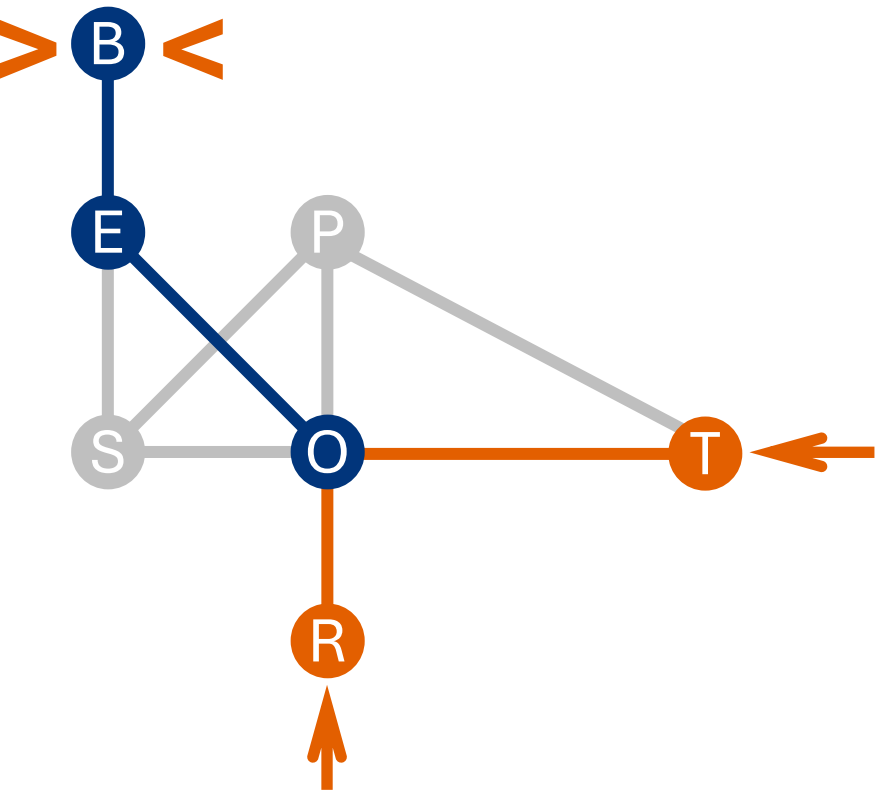

Holistically looking into the entire data pipeline...

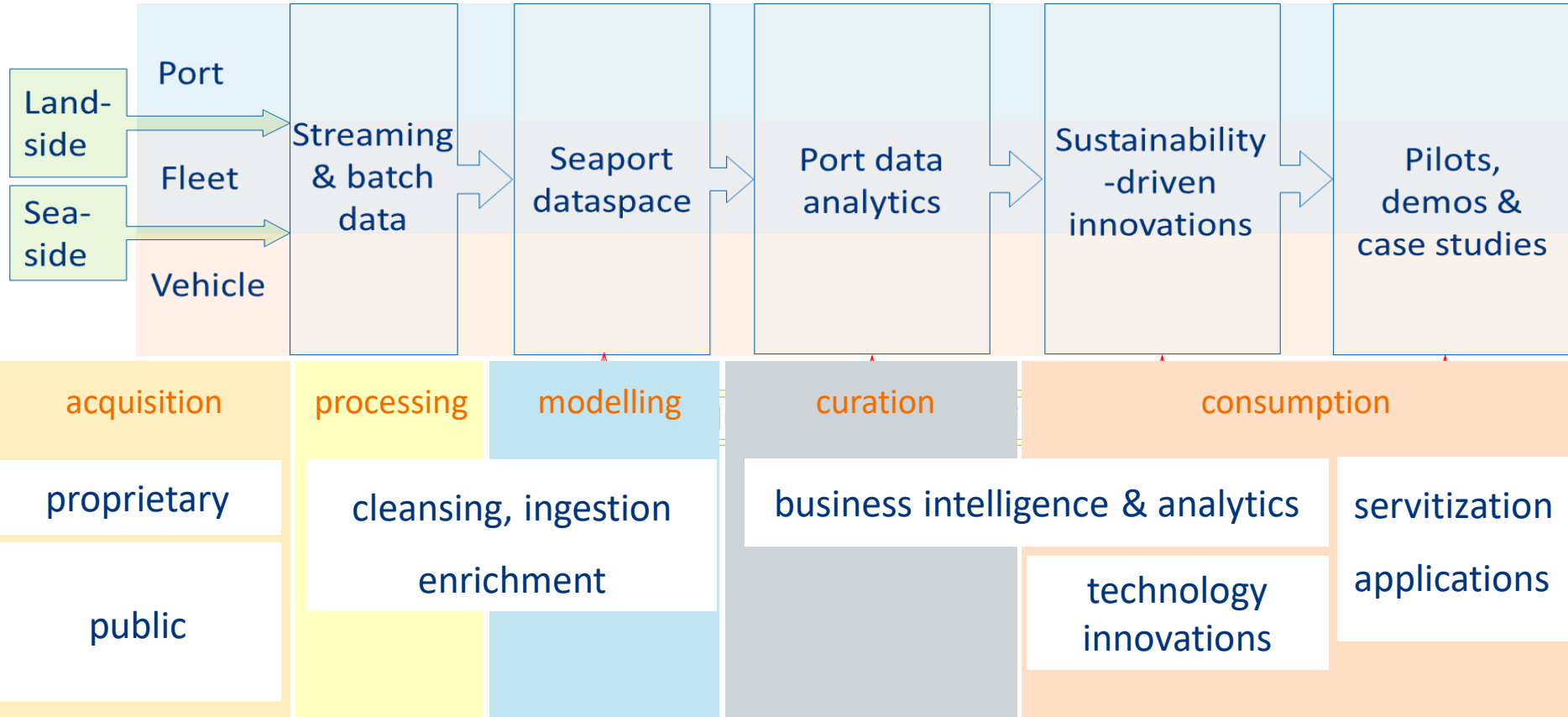

Digital & Green Ports Together!

9 INDUSTRY, INNOVATION AND INFRASTRUCTURE



11 SUSTAINABLE CITIES AND COMMUNITIES



13 CLIMATE ACTION



17 PARTNERSHIPS FOR THE GOALS

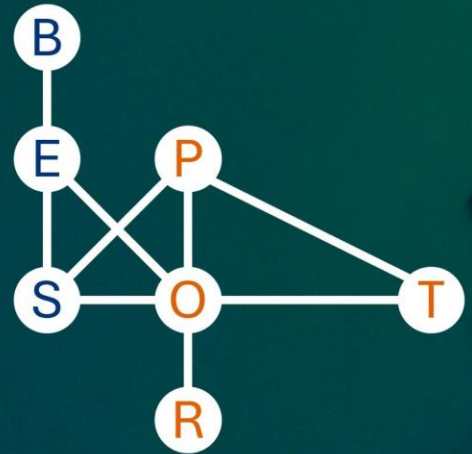

Innovation

Business

Platform



bey⁰nd

the obvious

ZOU Guangrong (Aron)
guangrong.zou@vtt.fi